

# LEGACY



**SUBARU**

*Confidence in Motion*







**Revel** in refinement.  
**Revel** in the moment.

You've worked hard for long enough. It's time for you to indulge more in life. Do more of what you like to do. Excel at your profession. Explore your interests. Pursue your passions. Subaru vehicles are designed to be the bond that holds everything together so you can spend more time connecting to what matters most in life, and the Legacy is no different. With the technology to support your life, a sporty feel to help you enjoy it, and the longevity for the long run, the Legacy is ready to help you make your mark in life.





## *Its goal –helping you realise yours.*

Unleash the power within to pursue what you want most. The Legacy reconnects you with the joy of driving with a sportier, more responsive ride and All-Wheel Drive capability to get you where you need to go with Symmetrical All-Wheel Drive. Its stylish looks are especially pleasing to the eye, whilst its well-appointed interior offers useful technology and plush materials that are pleasing to the touch. This sporty sedan caters to all your comforts and gives you free reign to indulge in true driving enjoyment.





## Extract *more joy out of every drive.*

Balanced and confident, the Legacy owes its sporty, high-performance nature to its SUBARU BOXER engine and the efficient Lineartronic Continuous Variable Transmission. With shift controls designed for smooth, exciting acceleration to enhance your driving enjoyment, the Lineartronic transmission complements the SUBARU BOXER engine, helping it achieve class-leading fuel efficiency and driving enjoyment at all times.

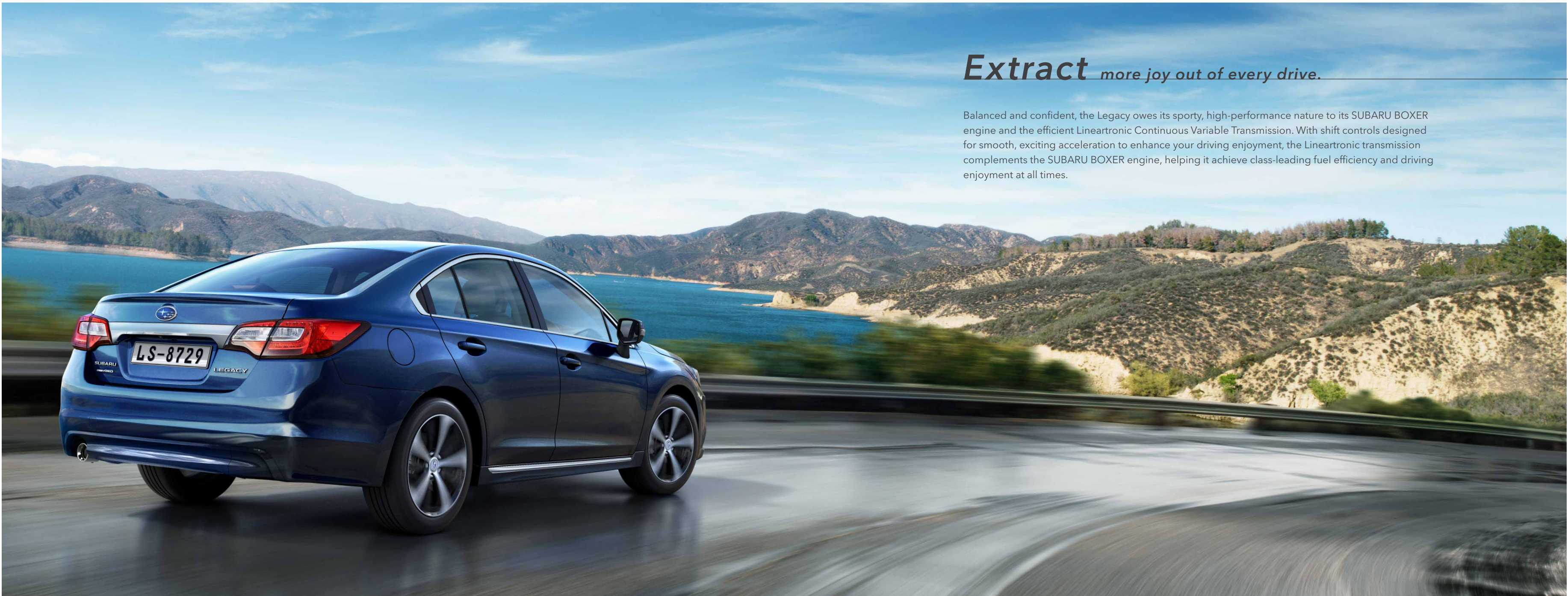

### Paddle Shifters

Paddle shifters are mounted on the steering wheel for fingertip control, giving you the power to select the gear ratio of the Lineartronic that best suits your driving situation. They also provide a six-step manual mode for quick response on demand. The result is a sharper and sportier driving experience.

### SI-DRIVE

Based on your driving style, SUBARU Intelligent Drive (SI-DRIVE) can adjust the throttle and shifting response to give you immediate power and agility when you crave it in nearly any scenario.



### Sport Sharp Mode\*

When you want powerful engine performance, select Sport Sharp Mode for quick acceleration and sharp response. Use the paddle shifters and take even more control. To enjoy sporty driving, this mode unleashes the engine's maximum potential.



### Sport Mode

This highly responsive mode is well suited to all-round conditions with its immediate acceleration. It puts the enjoyment back into high-speed driving on motorways or on winding roads.



### Intelligent Mode

Offering gentle power delivery, this mode is ideal for cruising around town on local streets, covering long distances, or achieving high fuel efficiency. It also provides flexible control in the rain or on snowy roads.

\* Available only on 3.6R-S.



# *Euphoria* is its defining feature.

True to its form, the Legacy was designed to excite. Strong character lines along the side and a more aggressive front end tell you this sedan was designed to deliver true driving enjoyment. With a stiffer chassis, retuned steering and suspension, as well as Active Torque Vectoring, the drive is also more responsive and more engaging than ever.





# *Rewarding to drive.*

*Rewarding to look at.*

You'll feel it at the first rush, that first grin as you enjoy immediate response and impressive control in the corners. The Legacy is sporty and aerodynamic in style, which also contributes to its impressive fuel consumption.





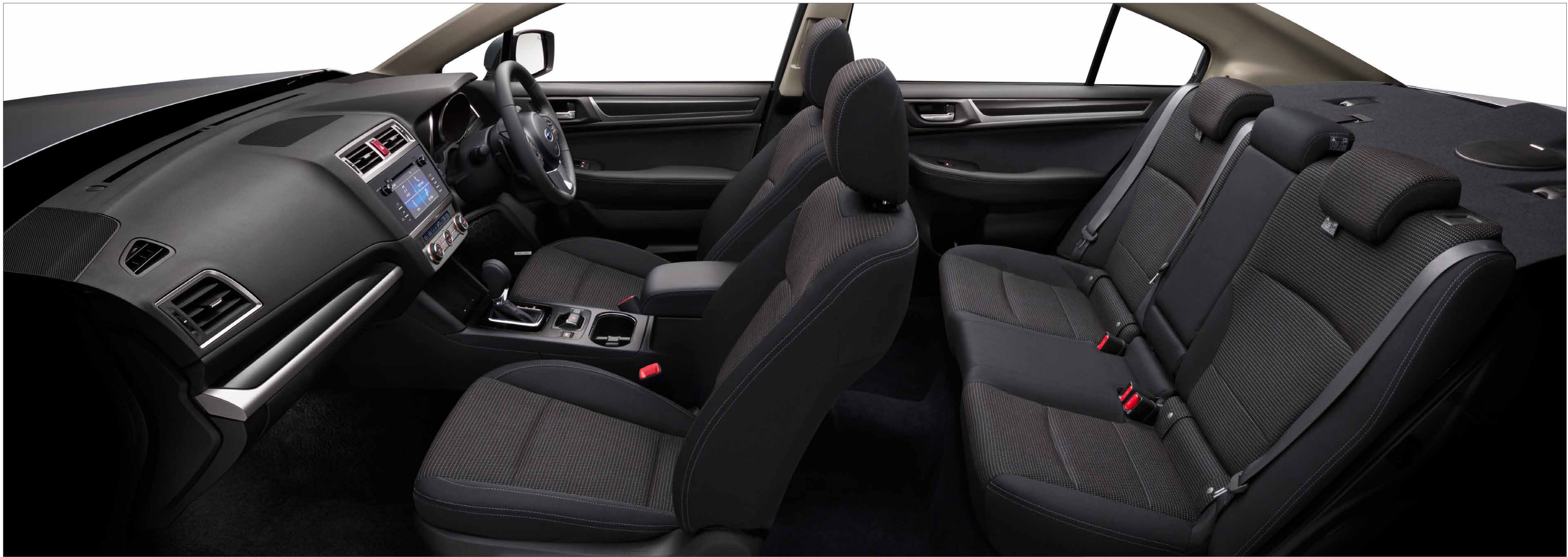

## Designed around its most important cargo—you.

Designed to optimise your driving pleasure, the cockpit has a sporty sedan feeling with upgraded materials and technology throughout. With a sport-contoured steering wheel, it's designed for more enthusiastic driving, whilst the seats are there to hold the driver firmly in place with strong support, so that the driver can focus on their driving enjoyment.



### 1 Comfortable rear seats

The cabin of the Legacy was designed to provide ample space for rear passengers for enhanced comfort on longer drives.



### 2 Large sunroof\*

Enjoy a more open feel with the large, panoramic sunroof. The inner sliding sunroof includes tilt-up and auto-reverse features to bring in plenty of light at your command.

\* Standard on 2.5i-S and 3.6R-S, optional on 2.5i.





# Technology

with a human touch.

Make your day-to-day brilliant. The ingenious design and technology of the Legacy work exceptionally well and are especially useful. A 7-inch centre touchscreen and LCD meter centre display give you access to it all. A premium audio system with 12 Harman/Kardon speakers or standard audio with six speakers is available for your enjoyment. Plus the entire infotainment system is compatible with smartphones, making it easy to stay connected.\*1

## 1 Voice Recognition\*2 and Siri Eyes Free\*3\*4

Your Legacy has more hands-free options than ever before, thanks to intuitive Voice Recognition\*2 and Siri Eyes Free\*3\*4 integration. Use Siri to link your compatible Apple\*4 product to your Legacy, allowing you to make hands-free calls, play music, check emails and search the web. Even without Siri, you can still have hands-free interaction with navigation, telephone and audio systems for added ease in every drive.

## 2 Touchscreen control

The touchscreen is a useful way to select your music, just as you would on your smartphone. Simply connect your smartphone through Bluetooth®\*5 or the USB port, and you can choose your music right on the touchscreen.

## 3 LCD meter centre display

The LCD meter centre display supplies the driver needed information at a glance without having to look to the side. It also features an efficiency display that allows you to track your fuel economy. It's the data you need to stay informed and confident that your drive stays as efficient as possible.

## 4 Harman/Kardon Audio System\*6

Featuring Harman/Kardon's latest technology, GreenEdge, the premium audio system in the Legacy includes 12 Harman/Kardon speakers and improved acoustics for a richer audio experience.



\*1 Driver is always responsible for safe and attentive driving. Please refrain from operating the touchscreen whilst driving.

\*2 Voice Recognition is compatible with select languages only and cannot accept all language.

\*3 Siri-compatible Apple product (iPhone, iPad, iPod touch, etc.) required. \*4 Apple, iPod, Siri and iTunes are registered trademarks of Apple Inc. App Store is a service mark of Apple Inc.

\*5 Bluetooth is a registered trademark of Bluetooth SIG, Inc. America. \*6 Standard on 2.5i-S and 3.6R-S.





## *Your partner* in life.

There's more cargo room to accommodate your daily demands, and should you need more room, the 60/40 folding rear seats can also adjust in an instant to make room for longer items and extra packages even with a passenger still riding in the rear seat.





# Symmetrical All-Wheel Drive

Control leads to confidence, and stability creates an agility that excites in the Legacy. Subaru vehicles are gifted at inspiring confidence behind the wheel, thanks to the inherently stable design of Symmetrical All-Wheel Drive paired with the uniquely balanced SUBARU BOXER engine. This system delivers power to all four wheels at all times for enhanced control on all roads and in poor conditions. It has excellent side-to-side balance and handling precision, thanks to its main components being aligned longitudinally, whilst its low centre of gravity creates an especially engaging and responsive drive. The unique advantages of Symmetrical AWD make for exceptionally rewarding handling and empower you to better avoid danger.

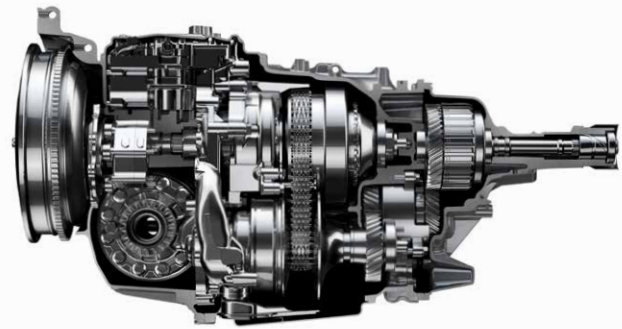

## Lineartronic

Designed to get the most out of your SUBARU BOXER engine and Symmetrical All-Wheel Drive, the efficient Lineartronic Continuously Variable Transmission keeps the engine in its ideal power range to give the Legacy its class-leading fuel consumption. The shift controls keep the ride light, smooth and responsive on both the 2.5-litre and 3.6-litre engines, whilst the Lineartronic in 3.6R-S also handles the higher-torque output with less mechanical noise for a smoother, quieter drive. The shift controls have a stepped variable control that stays in tune with changes in vehicle speed and engine speed, allowing the driver to feel shift points when accelerating to form a strong and comfortable connection between car and driver.

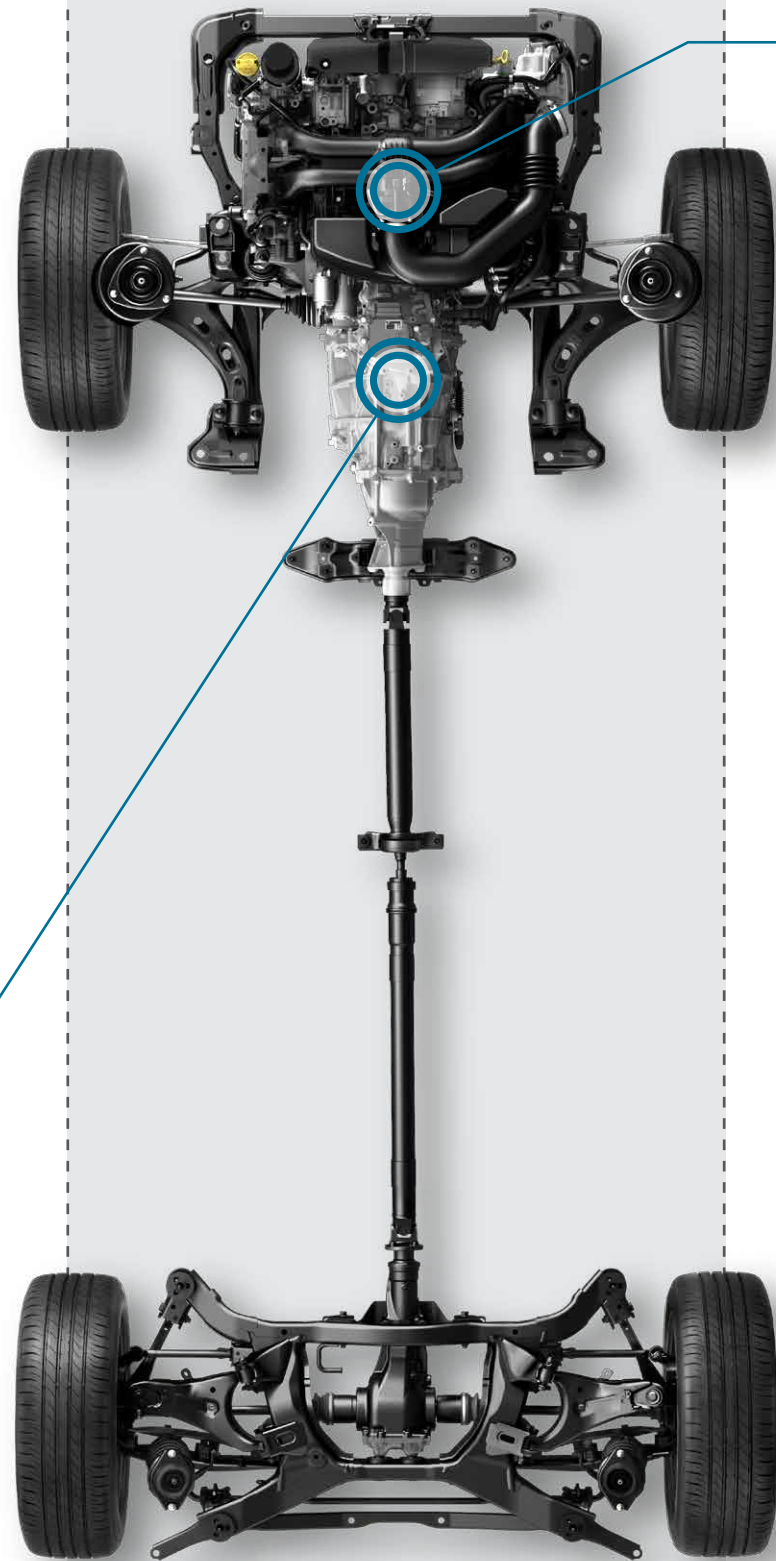

## SUBARU BOXER Engine

Few other cars drive with the self-assured confidence of the Legacy, so you won't be surprised by how uniquely it is accomplished. The horizontally opposed configuration of the SUBARU BOXER engine places the pistons 180 degrees apart, for a lower, flatter profile than other engine types. This gives the engine, and therefore the overall vehicle, a lower centre of gravity and better sense of balance. Further, the pistons' opposing movements inherently counteract each other, naturally helping to reduce vibration.



### 3.6-litre DOHC SUBARU BOXER

**MAX OUTPUT:**  
191 kW (260 PS) /  
6,000 rpm

**MAX TORQUE:**  
350 Nm (35.7 kgfm) /  
4,400 rpm

**FUEL CONSUMPTION\*:**  
9.9 lit./100 km

**CO<sub>2</sub> EMISSIONS\*:**  
230 g/km

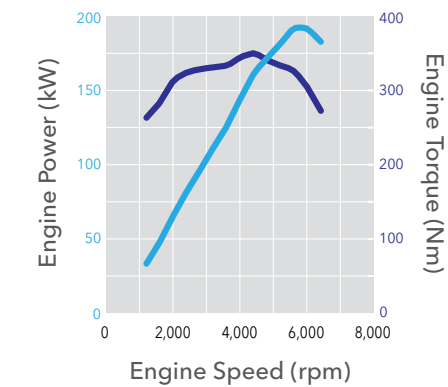

### 2.5-litre DOHC SUBARU BOXER

**MAX OUTPUT:**  
129 kW (175 PS) /  
5,800 rpm

**MAX TORQUE:**  
235 Nm (24.0 kgfm) /  
4,000 rpm

**FUEL CONSUMPTION\*:**  
7.7 lit./100 km

**CO<sub>2</sub> EMISSIONS\*:**  
177 g/km

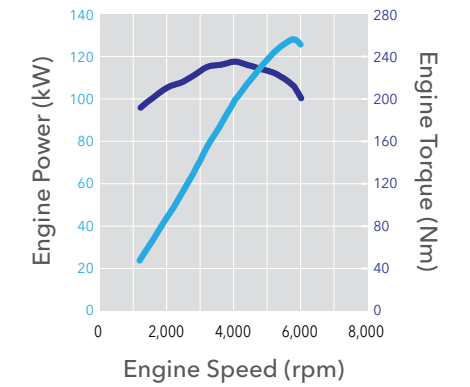

## Long-lasting performance

The engine's flat design is inherently rigid and self-balancing to achieve durability and reliable performance, generating less vibration than V-type or 4-cylinder in-line engines in the same class.

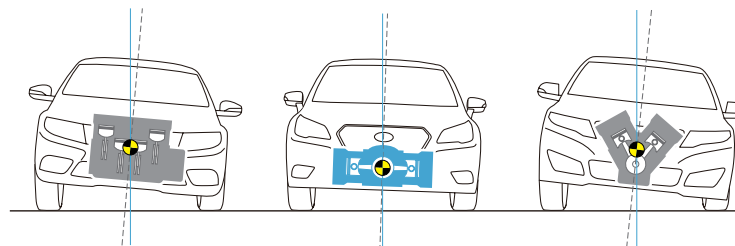

## Increased stability

Because the engine block has a flatter profile and sits lower in the chassis, the overall vehicle is more stably balanced and resistant to side-to-side motion than other designs.

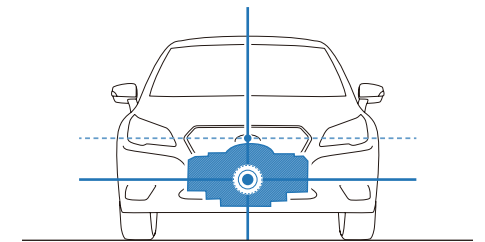

\* Fuel consumption and CO<sub>2</sub> emissions: According to ECE R101-01.



# Proactive and Protective.

Knowing the importance of all that's aboard, the Legacy does a lot to protect you and your passengers with high-quality safety systems like seven SRS\*1 airbags, Ring-shaped Reinforcement Frames, and even a cabin protecting layout. There may be risks in life, but we make sincere efforts to make sure that what you value most is well protected in your Legacy.



## Ring-shaped Reinforcement Frame

The Ring-shaped Reinforcement Frame strengthens the passenger cabin from the roof to the doors, pillars and floor. This design works to divert and dissipate impact energy away from the occupants in a collision. It also contributes to strengthening and lightening the chassis, leading to greater, reinforced protection.

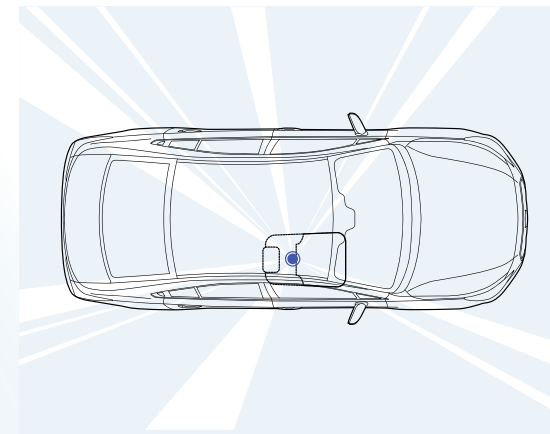

## Increased visibility

We adjusted the frame to increase your visibility and decrease your blind spot area. We also installed front quarter windows with door-mounted side mirrors to reduce the front blind spot for increased forward visibility.

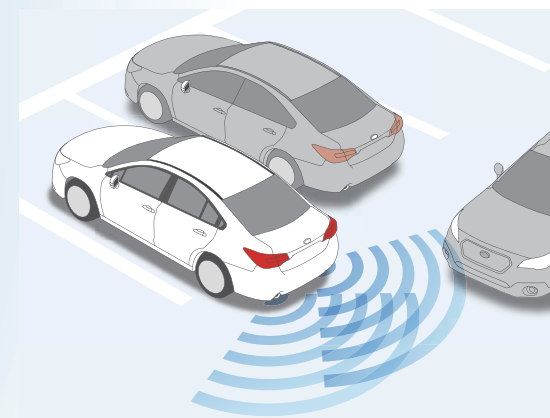

## Advanced Safety Package\*2

For increased awareness and visibility, the Advanced Safety Package includes two innovative new features—High Beam Assist (HBA) and Subaru Rear Vehicle Detection (SRVD). HBA can automatically toggle between high and low beams depending on road conditions such as speed and oncoming traffic, enhancing visibility for you, and other drivers as well. SRVD uses sensors placed around the vehicle to alert you of vehicles in your rear blind spots for safer lane changes, and can also warn you of potential collision danger whilst driving in reverse into a street with cross traffic.

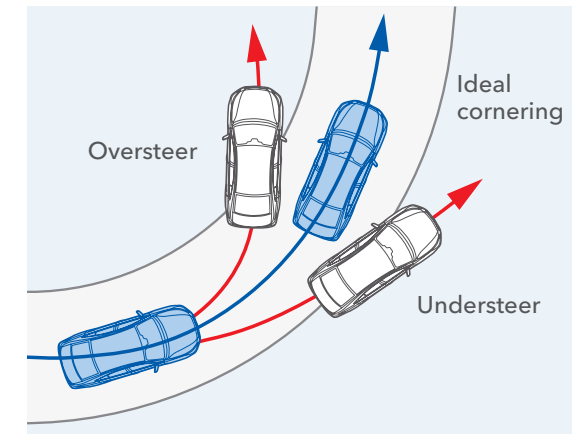

## Vehicle Dynamics Control System

Vehicle Dynamics Control System monitors and analyses if the vehicle is following the driver's intended course via an array of sensors. If a tyre slips or a high-speed turn moves the vehicle off its intended path, the AWD torque distribution, engine output and brakes at each wheel are adjusted to assist in keeping the vehicle on course.

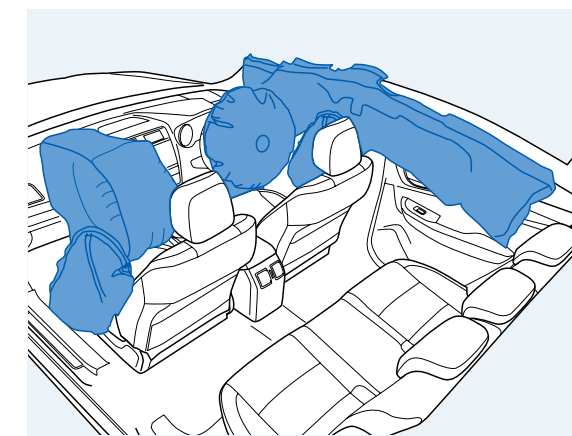

## Seats, seatbelts and SRS\*1 airbags

Standard on Legacy are front SRS\*1 airbags, plus front-side SRS\*1 airbags, curtain SRS\*1 airbags and knee SRS\*1 airbags. Height-adjustable front seatbelts feature pretensioners to hold passengers firmly in place, and load limiters that ease peak forces to the chest.

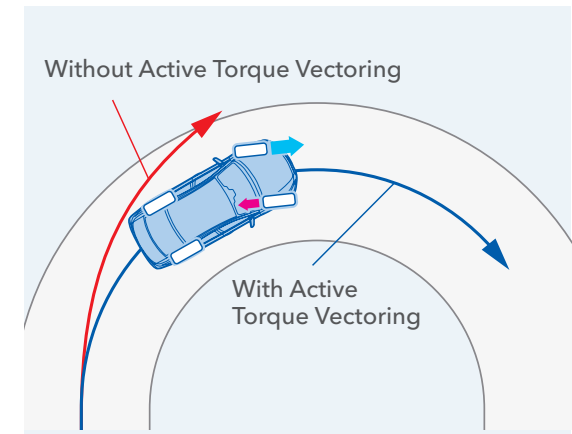

## Active Torque Vectoring

When cornering, Active Torque Vectoring applies the brakes and distributes less torque to the inside wheels and more torque to the outside wheels. It helps make a sharp turn and handling more precise. In combination with Vehicle Dynamics Control System, it helps to keep you out of harm's way, granting you a comforting sense of security.

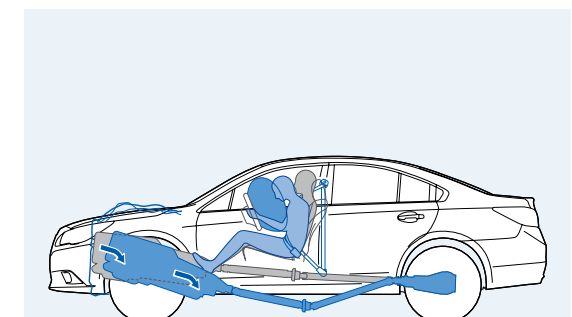

## Cabin-protecting layout

Every Subaru goes above and beyond common practice when it comes to your safety. In the event of a head-on collision, your Legacy's SUBARU BOXER engine and gearbox are designed to avoid moving into the cabin for your protection.

\*1 SRS: Supplemental Restraint System. Effective when used in conjunction with seatbelts. \*2 Standard on 2.5i-S and 3.6R-S.



### LEGACY 3.6R-S

Dimensions: L x W x H: 4,795 x 1,840 x 1,500 mm  
Engine: Horizontally opposed, 6-cylinder, DOHC, 24-valve, petrol  
Capacity: 3,630 cc  
Max output: 191 KW (260 PS) / 6,000 rpm  
Max torque: 350 Nm (35.7 kgfm) / 4,400 rpm  
Transmission: Lineartronic, AWD



Ice Silver Metallic

### LEGACY 2.5i-S

Dimensions: L x W x H: 4,795 x 1,840 x 1,500 mm  
Engine: Horizontally opposed, 4-cylinder, DOHC, 16-valve, petrol  
Capacity: 2,498 cc  
Max output: 129 KW (175 PS) / 5,800 rpm  
Max torque: 235 Nm (24.0 kgfm) / 4,000 rpm  
Transmission: Lineartronic, AWD



Lapis Blue Pearl

### LEGACY 2.5i

Dimensions: L x W x H: 4,795 x 1,840 x 1,500 mm  
Engine: Horizontally opposed, 4-cylinder, DOHC, 16-valve, petrol  
Capacity: 2,498 cc  
Max output: 129 KW (175 PS) / 5,800 rpm  
Max torque: 235 Nm (24.0 kgfm) / 4,000 rpm  
Transmission: Lineartronic, AWD



Platinum Grey Metallic





LEATHER IVORY (3.6R-S)



LEATHER BLACK (3.6R-S)



FABRIC IVORY (2.5i-S)



FABRIC BLACK (2.5i-S)



FABRIC BLACK (2.5i)



- 1 LED headlamps with auto leveliser\***  
Get maximum illumination the instant you turn these headlamps on, and the auto-leveliser will adjust the headlamps to keep them pointed at the correct angle for optimum visibility. The welcome lamps also turn on automatically when you're entering or exiting the car, to enable you to move safely even in the dark.
- 2 Twin tail muffler**  
Available on the Legacy 3.6R-S, these enlarged tail mufflers hint at the sporty performance within.
- 3 18-inch aluminium alloy wheels**  
Multi-spoke 18-inch aluminium-alloy wheels have a Legacy-exclusive, rugged appearance and an aerodynamic design for improved fuel efficiency. Together with the 225/50R18 high-performance tyres, they make an attractive addition to the Legacy 2.5i-S and 3.6R-S models.
- 4 Automatic rain-sensing windshield wipers**  
When rainfall is detected, the available automatic windshield wipers will turn on and adjust their wiping intervals and speed accordingly.
- 5 Tilt-adjustable/Telescopic steering wheel**  
To help ensure you're comfortable whilst driving, the adjustable steering wheel tilts up and down, and telescopes in and out.
- 6 Rear ventilation system**  
Offering added comfort for rear passengers, the Legacy models include adjustable rear-cabin air vents on the back of the centre console box.
- 7 8-way power adjustable driver's seat (with lumbar support)\***  
Find your ideal driving position with this 8-way power adjustable driver's seat.
- 8 Keyless access with push-button start system\***  
Your key fob grants you complete keyless access. To lock/unlock the front doors or trunk, simply grip the door handles. To start the engine, push the button. Using a 5-digit PIN code allows you to enter your Subaru even without your key fob.

\* Standard on 2.5i-S and 3.6R-S, optional on 2.5i.



## Make your Legacy truly yours.

Tailor your Legacy to you and your lifestyle with SUBARU accessories. Add convenience, enhance functionality, or personalise your Legacy's appearance, all with SUBARU accessories designed with the same fit and quality as your SUBARU vehicle. For more details, ask for the accessory brochure or visit your nearest SUBARU dealer.

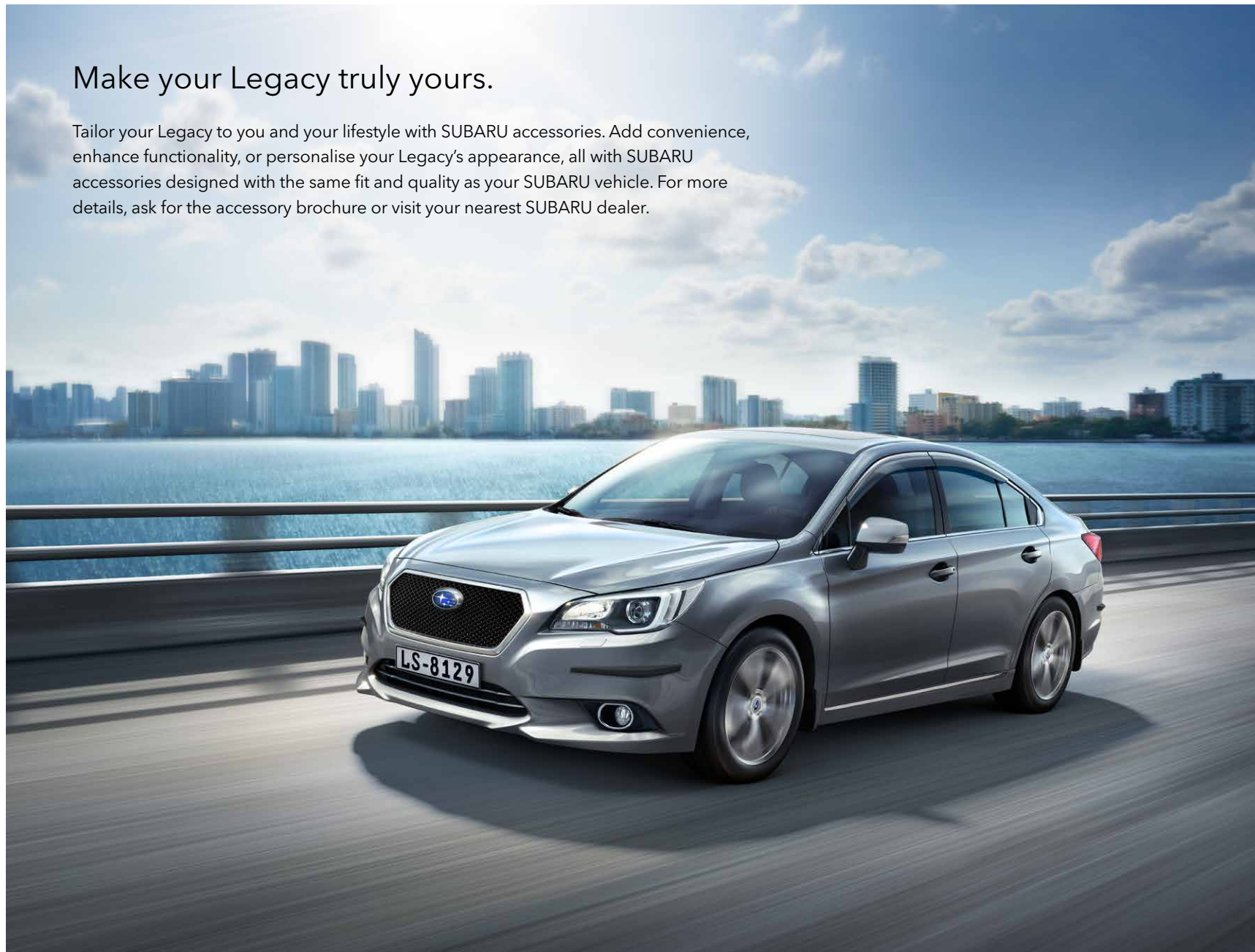

Front Grille

Body Side Molding

Door Visor

Splash Guard

Trunk Tray

## SUBARU Interactive Experience

To help you explore all things Subaru, we offer various digital materials with a wide range of exciting, interactive content such as 360-views and videos.

### eBrochure

Experience the Subaru dynamic eBrochure for more details, including videos, photos and more.

[subaru-global.com/ebrochure](http://subaru-global.com/ebrochure)

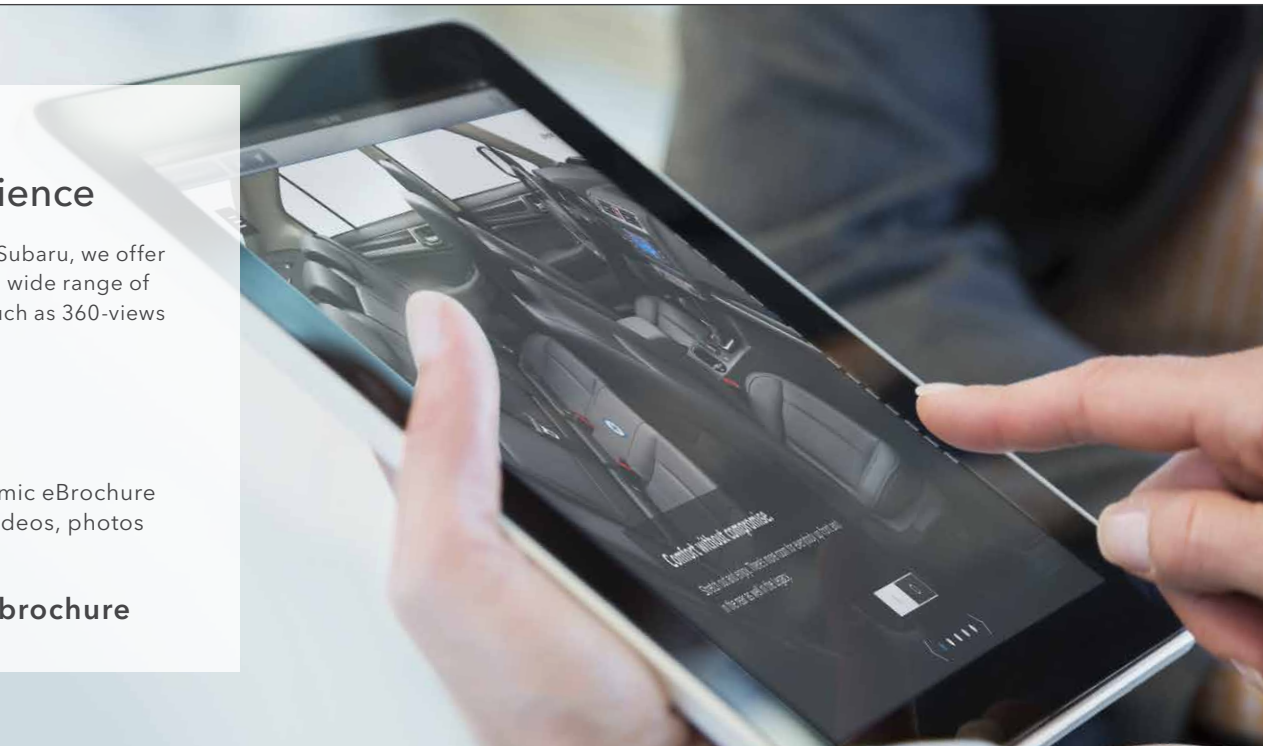

**SUBARU**  
*Confidence in Motion*

### Web Homepage

Visit our global homepage for complete information and news about Subaru and our vehicles.

[subaru-global.com](http://subaru-global.com)



### YouTube

Subscribe to our channel to see all the latest videos and join the conversation about Subaru.

[youtube.com/user/SubaruGlobalTV](https://youtube.com/user/SubaruGlobalTV)



### Facebook

Stay connected to our diverse Subaru community and be the first to hear the latest news directly from Subaru.

[facebook.com/SUBARU.GLOBAL](https://facebook.com/SUBARU.GLOBAL)

## DIMENSIONS

Dimensions are measured in accordance with standard measurement of Fuji Heavy Industries Ltd.

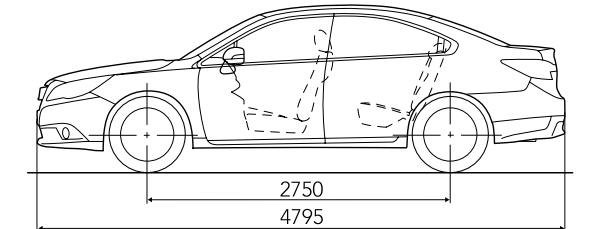
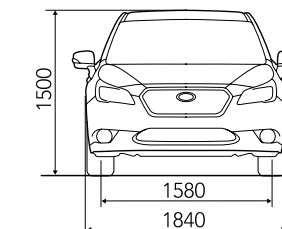

Fuji Heavy Industries Ltd. reserves the right to alter specifications and equipment without notice. Details of specifications, equipment, colour availability and the accessory lineup are subject to suit local conditions and requirements. Please inquire at your local dealer for details of any changes that might be required for your area.





**SUBARU**

*Confidence in Motion*

**FUJI HEAVY INDUSTRIES LTD.**  
subaru-global.com

Printed in Japan (16BR BKC 2015.12)